

## MAXIMUM POWER POINT TRACKING TECHNIQUES FOR PHOTOVOLTAIC WATER PUMPING SYSTEM

M.VIJAY,  
Master of engineering  
in  
Power Electronics and Drives  
Department of EEE,  
Gnanamani College of Engineering,  
Namakkal – 637018,

### ABSTRACT

An investigation into the design of a standalone photovoltaic water pumping system for supplying rural areas is presented. It includes a study of system components and their modelling. The PV water pumping system comprises a solar cell array, DC DC buck chopper and permanent magnet DC motor driving a centrifugal pump. The thesis focuses on increasing energy extraction by improving maximum power point tracking (MPPT). P&O MPPT algorithm is investigated which uses to automatically adjust stepsize to better track maximum power point. These use PV source output power and the speed of the DC pump motor as input variables. Bot generate pulse width modulation (PWM) control signals to continually adjust the buck converter to maximize power from the PV array, and thus motor speed and the water discharge rate of a centrifugal pump. System elements are individually modelled in MATLAB/SIMULINK and then connected to assess performance under different PV irradiation levels. First, the MP&O MPPT technique is compared with the conventional direct method. The results show that the MP&O MPPT has faster dynamic response and eliminates oscillations around the MPP under steady state conditions. The three proposed MPPT methods are implemented in the simulated PV water pumping system and compared. The results confirm that the new methods have improved energy extraction and dynamic tracking compared with simpler methods.

Keyword: pv,MPPT, DC- DC buck chopper ,PWM, permanent magnet DC motor and centrifugal pump.

### INTRODUCTION

The stand-alone photovoltaic (PV) water pumping system has received increasing attention in the last 20 years because of the significant, on-going cost reductions achieved in manufacturing PV arrays. Past studies of PV energised water pumping systems have previously considered a number of suitable pumps and motors. Two types of pumps are widely employed in PV systems: the centrifugal pump and volumetric pump. The centrifugal pump is capable of pumping a high volume of water and operating at relatively high efficiency. These pumps are used to pump the water from boreholes and from surface water reservoir and they are ideally suitable for medium to high water demands.

There are two categories of centrifugal pumps are commercially available: submersible (stacked impeller) and non-submersible (vertical turbine, floating, and surface centrifugal). Similarly, there are two types of volumetric pumps are commercially available and they categorised: submersible (diaphragm) and non-submersible (piston, jack, and rotary vane). The volumetric pumps are usually used when a low flow rate is require. The centrifugal pumps have operational characteristics which well match with the PV array. However, the operational characteristics of the volumetric pumps are not a good match to the output of PV array. This is because the motor driving volumetric pump requires high starting current and they require constant current for a given head. Whereas, the PV array current varies almost linearly with the solar radiation.

## Photovoltaic cell

The structure of solar cells is illustrated in Fig. 3.2. A semiconductor of p-type with a small quantity of added boron atoms forms the substrate. Then atoms of phosphorous are added to the substrate to form a p-n junction by applying high-temperature diffusion processing. Near the junction of the two semiconductors, the electrons from the n-side diffuse into the p-side leaving behind a layer of ions with positive charge in the n-side.

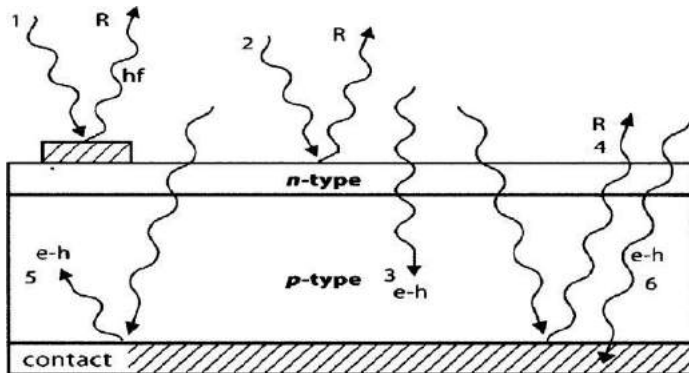

Figure 1. photovoltaic cell

The growth of such technology depends on materials and structure development; however the goal will always be maximum power at minimum cost. In any structure, solar cells, which are connected in series and in parallel in order to form the desired voltage and current levels, remain the basic semiconductor components of a PV panel. To maximize the power rating of a solar cell which ensures the highest efficiency, hence designed to raise the desired absorption and absorption after reflection (Fig. 1). This chapter will briefly describe the principles and history of photovoltaic (PV) energy systems and will explore in details the various available technologies while reflecting on the advancement of each technology and its advantages and disadvantages and photovoltaic applications. Included are discussions of the status, development and applications of various PV and solar thermal technologies. This chapter is a full review on the development of existing photovoltaic (PV) technology. It highlights the four major current types of PV: crystalline, thin film, compound and nanotechnology. The aim of continuous development of PV technology is not only to improve the efficiency of the cells but also to reduce production cost of the modules, hence make it more feasible for various applications. In the same manner, the holes in the p region diffuse into the n region, which leaves behind a layer of ions with negative charge in the p-side. A potential barrier is formed from the rearranged positively and negatively charged ions. The most popular model used to represent the PV module is the current source in parallel with a diode, with a parallel and series resistors ( $R_p$ ,  $R_s$ ) as illustrated in figure 1.

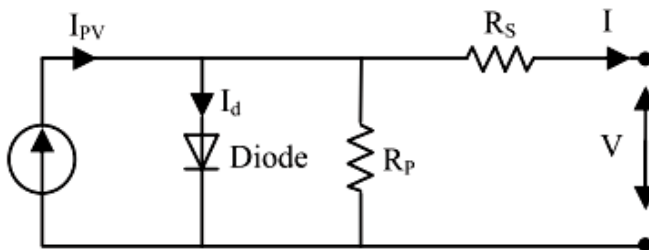

Figure 2. Equivalent Circuit of pv cell

There are various mathematical models that have been discussed in the literature to theoretically model photovoltaic cells. All of these models give an approximate behaviour of the solar cell. The accuracy of each model is classified according to how many internal phenomena are considered. The basic solar cell is usually represented by a p-n junction diode connected in parallel with current source. This conventional equivalent circuit as illustrated in Fig. The basic model does not provide a high range of accuracy but it shows the basic behaviour of the solar cell.

The current source represents the photocurrent produced by sunlight and the diode determines the current-voltage characteristic of the cell. The current-voltage characteristic function can be gained by applying Kirchoff's current law in Fig. 3.4 which gives Equation .

$$I_{PV} = I_{Ph} - I_D$$

In the circuit above shown in Fig. 3.4,  $D_j$  is the ideal p-n diode,  $I_D$  the diode internal diffusion current and  $I_{Ph}$  the photocurrent, or light generated current, which is proportional to the radiation and surface temperature.

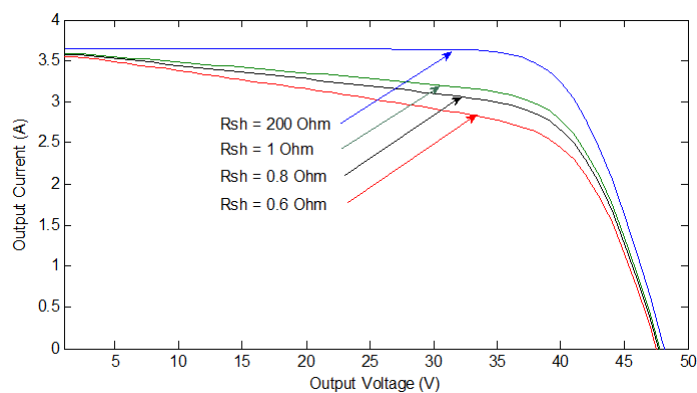

Figure .3 Effect of shunt resistance on the I-V characteristic.

The output current and voltage of the solar cell is represented by  $I_{PV}$  and  $V_{PV}$ , respectively. The diode internal diffusion current is modelled by Equation . Where  $q$  is the charge of electron,  $1.6 \times 10^{-19}$  C,  $A$  is diode ideality factor and it takes the value between 1 and 2,  $k$  is Boltzmann's constant,  $1.38 \times 10^{-23}$  J/K, and  $T_C$  is the cell's operating temperature in kelvin. The cell dark saturation current,  $I_S$ , varies with temperature according to Equation (3.4). The photocurrent,  $I_{Ph}$ , is related to the cell's operating temperature and solar intensity as shown in Equation .

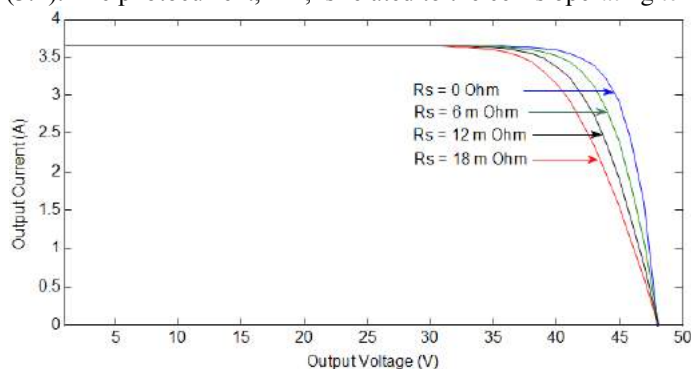

Figure 4. Effect of series resistance on the I-V characteristic.

#### MAXIMUM POWER POINT TRACKING (MPPT)

Maximum Power Point Tracking, frequently referred to as MPPT, is an electronic system that operates the Photovoltaic (PV) modules in a manner that allows the modules to produce all the power they are capable of. MPPT is not a mechanical tracking system that “physically moves” the modules to make them point more directly at the sun. MPPT is a fully electronic system that varies the electrical operating point of the modules so that the modules are able to deliver maximum available power. Additional power harvested from the modules is then made available as increased battery charge current. MPPT can be used in conjunction with a mechanical tracking system, but the two systems are completely different.

To understand how MPPT works, let's first consider the operation of a conventional (non- MPPT) charge controller. When a conventional controller is charging a discharged battery, it simply connects the modules directly to the battery. This forces the modules to operate at battery voltage, typically not the ideal operating voltage at which the modules are able to produce their maximum available power. The PV Module Power/Voltage/Current graph shows the traditional Current/Voltage curve for a typical 75W module at standard test conditions of 25°C cell temperature and 1000W/m<sup>2</sup> of insolation.

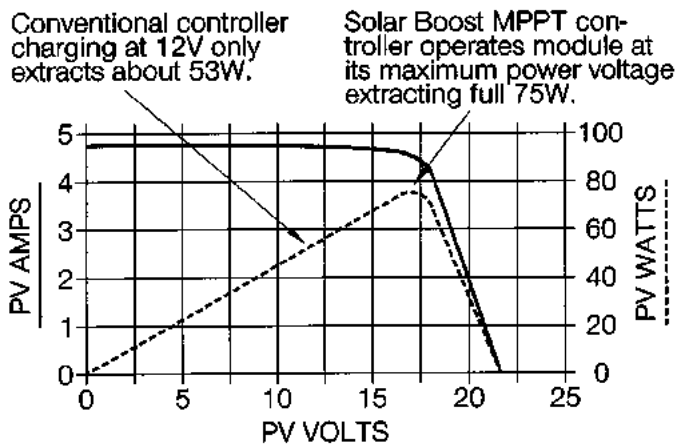

Figure 5. Typical 75W PV Module Power/Voltage/Current At Standard Test

Actual charge current increase varies with operating conditions. As shown above, the greater the difference between PV module maximum power voltage VMP and battery voltage, the greater the charge current increase will be. Cooler PV module cell temperatures tend to produce higher VMP and therefore greater charge current increase.

This is because VMP and available power increase as module cell temperature decreases as shown in the PV Module Temperature Performance graph. Modules with a 25°C VMP rating higher than 17V will also tend to produce more charge current increase because the difference between actual VMP and battery voltage will be greater. A highly discharged battery will also increase charge current since battery voltage is lower, and output to the battery

during MPPT could be thought of as being “constant power”.

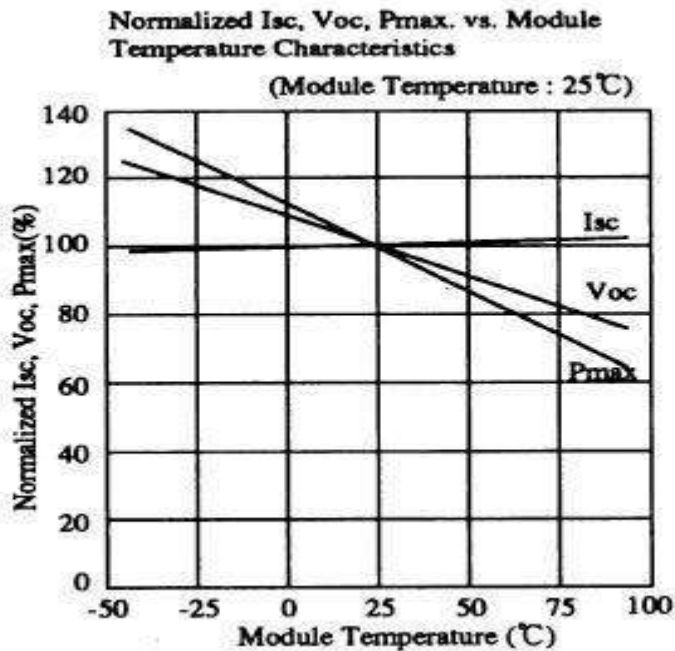

Figure 6. Typical PV Module Temperature Performance

#### MPPT ALGORITHM

There are a large number of algorithms that are able to track MPPs. An improved method for INC on the basis of variable step is presented. Some of them are simple, such as those based on voltage and current feedback, and some are more complicated, such as perturbation and observation (P&O) or the incremental conductance (IncCond) method. They also vary in complexity, sensor requirement, speed of convergence, cost, range of operation, popularity, ability to detect multiple local maxima, and their applications.

Having a curious look at the recommended methods, hill climbing and P&O are the algorithms that were in the center of consideration because of their simplicity and ease of implementation. Hill climbing is perturbation in the duty ratio of the power converter, and the P&O method is perturbation in the operating voltage of the PV array.

However, the P&O algorithm cannot compare the array terminal voltage with the actual MPP voltage, since the change in power is only considered to be a result of the array terminal voltage perturbation. As a result, they are not accurate enough because they perform steady-state oscillations, which consequently waste the energy [8]. By minimizing the perturbation step size, oscillation can be reduced, but a smaller perturbation size slows down the speed of tracking MPPs. Thus, there are some disadvantages with these methods, where they fail under rapidly changing atmospheric conditions [19].

**International Journal of Advanced Research in Basic Engineering Sciences and Technology (IJARBEST)**  
**Vol.3, Special Issue.24, March 2017**

```

MATLAB Functions script for P&O Algorithm
function D_k = fun (D_k2,D_k1,V_k,V_k1,I_k,I_k1,ds)
P_k1=I_k1*V_k1;
P_k=I_k*V_k;
dP=P_k1-P_k;
dD=D_k2-D_k1;
if dP>0
    if dD>0
        D_k=D_k2+ds;
    Else
        D_k=D_k2-ds;
    End
else
    if dD>0
        D_k=D_k2-ds;
    else
        D_k=D_k2+ds;
    end
end
%P_k=P_k1
%D_k2=D_k1

```

#### System design and simulation

The system has been modelled and simulated in MATLAB/SIMULINK. The complete SIMULINK model of the proposed system is illustrated in Fig. The modelled system consists mainly of PV array model, DC/DC buck converter model used to interface PV output to the resistive load to track the maximum power of the PV array. To perform the tracking of maximum power, a modified perturbation and observation algorithm has been implemented.

#### Comparative performance between MP&O and Direct method

In this section, a comparative analysis between MP&O and DM is carried out to show the performance of the both techniques in the same condition. The comparative study considers two important features: the maximum power point tracking speed and steady-state oscillation. To show the performance of the proposed MP&O MPPT algorithm with the DM MPPT algorithm in the steady-state and dynamic condition, the DM was tested with two different duty ratio step-sizes, 0.01 and 0.04. The output performance of the proposed MP&O MPPT and the DM MPPT with fixed step-size of 0.01 and 0.04 under three step changes of in irradiation levels.

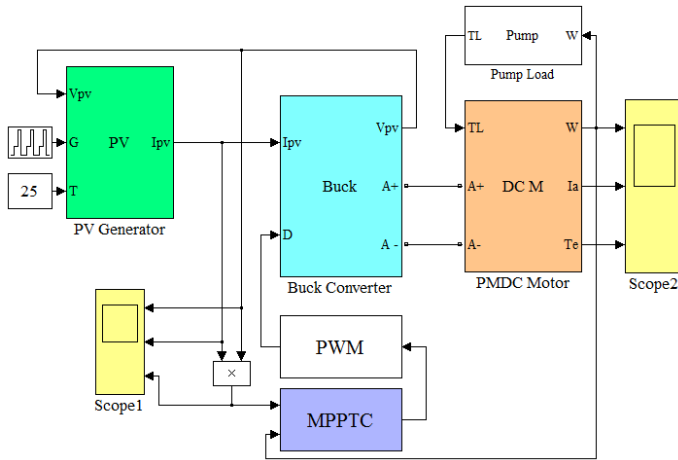

Figure 7. Simulation model diagram

The irradiation was abruptly changed from 1000 to 700 W/m<sup>2</sup> at 1s and then increased to 900 W/m<sup>2</sup> at 2s and then decreased back to 700 W/m<sup>2</sup> at 3s as shown in Fig. 3.1. Compared with the DM with fixed step-size of 0.01, the P&O MPPT with fixed step-size of 0.04 shows a good dynamic performance, it can converge faster to the steady-state but the oscillation in the steady-state is much higher. The tracking time of DM with fixed step-size of 0.04 under an irradiation step change is only several MPPT sampling periods. It takes 0.015s to reach the MPP, while the DM with fixed step size of 0.01 takes 0.037s to track the MPP as shown in Fig. 3.1.

The dynamic performance of the DM algorithm can be further improved with a larger step-size. However, this will have a negative effect on the MPPT efficiency. Fig. 7.21 to Fig. 7.2 prove that the proposed MP&O MPPT method with variable step-size can eliminate the need to perform a complicated trade-off between the steady-state and dynamic performance. Fig. 7.2 shows that the steady-state oscillation has been totally eliminated in the case of the MP&O and the output power of PV array is above 179.9 W. In addition the proposed MP&O MPPT provides faster dynamic response than the P&O MPPT at both step sizes of 0.01 and 0.04, as shown in Fig. 7.2 and Fig. 7.2

The efficiency of the MP&O MPPT method is clearly improved in comparison with P&O MPPT method with both step sizes of 0.01 and 0.04. Table 7.3 provides a summary of tracking performance for the MP&O MPPT and P&O MPPT methods with different levels of illumination. Furthermore, the tracking efficiency comparison of the proposed MP&O with the DM algorithm with step size of 0.04 and 0.01 is displayed in Fig. 7.25. However it should be noted that the efficiency is calculated based on a simulation that represented a short operating time. In practice, the PV array will operate all day. Hence the oscillation effect will be accumulated, and as a result the total efficiency of the MP&O method will be higher than the P&O method. In order to compare the performance of the MP&O against the conventional P&O in tracking the maximum power, the simulation power of the PV array is compared to the calculated power at the theoretical MPP for the same level of solar irradiation.

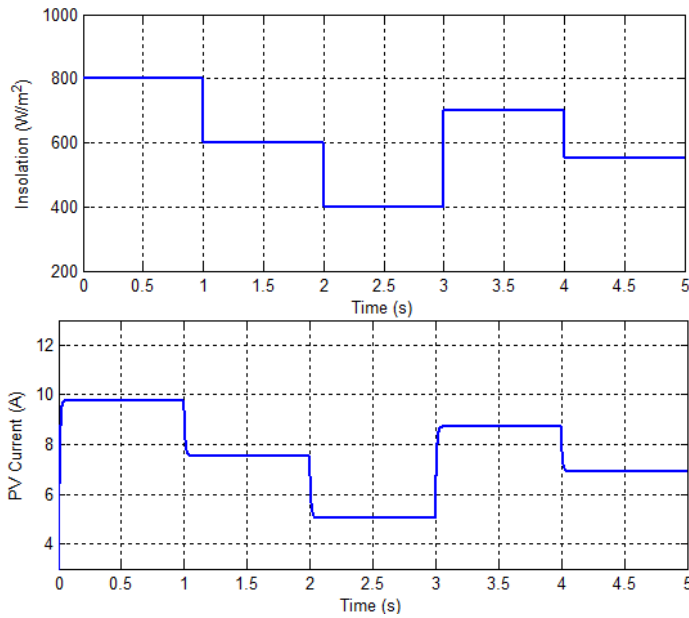

Figure. 7.1 Solar Irradiation

Figure 7.2 PV array output current without MPPT under varying irradiation

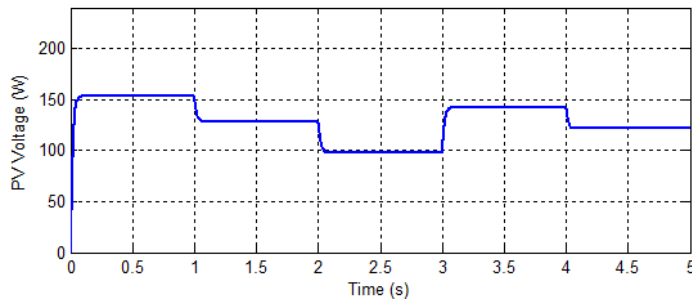

Figure 7.3 PV array output voltage under varying irradiation without MPPT

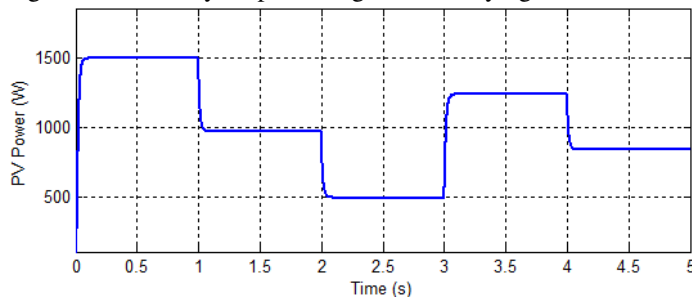

Figure 7.4 PV array output power varying irradiation without using MPPT



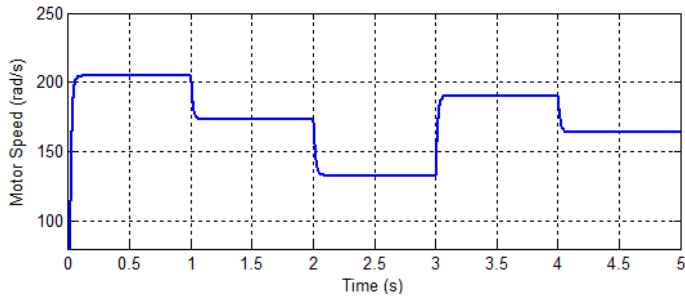

Figure 7.5 Rotational speed under varying irradiation levels without MPPT controller

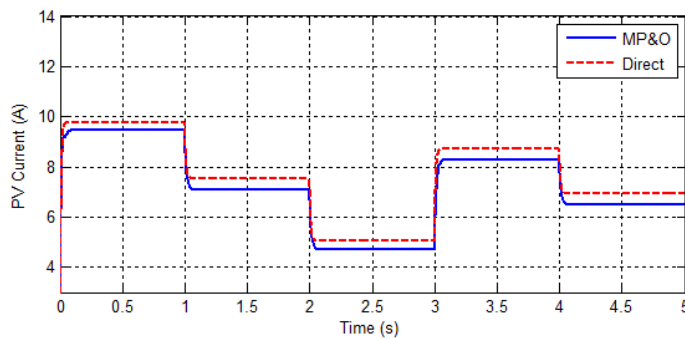

Figure 7.6 PV array output current under varying irradiation levels for MP&O MPPT.

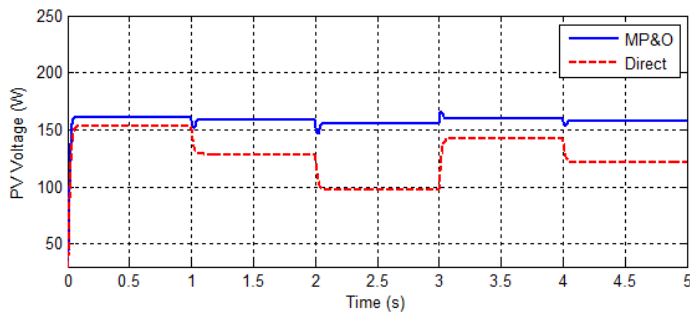

Figure 7.7 PV array output voltage under varying irradiation levels for MP&O MPPT

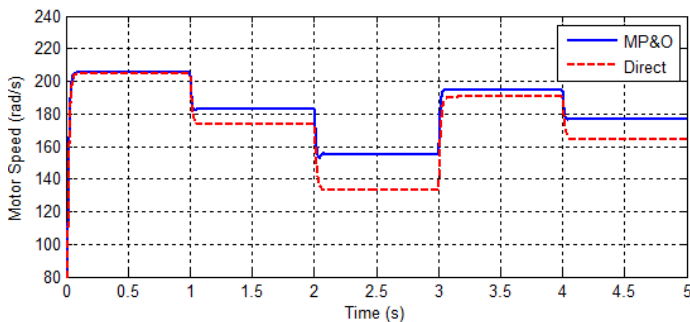

Figure 7.8 Rotational speed under varying irradiation levels for MP&O MPPT

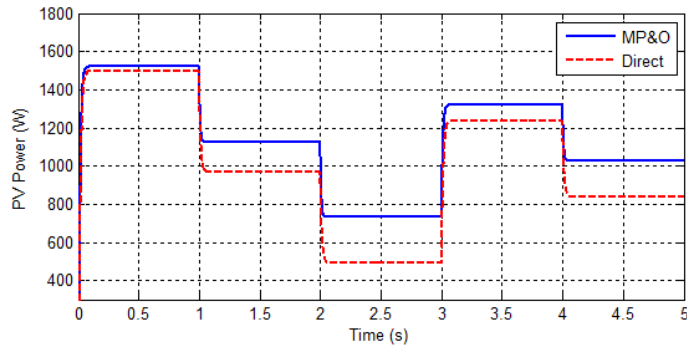

Figure 7.9 Pv Power under varying irradiation levels for MP&O MPPT

## CONCLUSION

In this research, a stand-alone photovoltaic water pumping system is presented to supply the water in remote location areas with a clean and sustainable source of energy. The main focuses of this research was how to improve the total system efficiency by implementing an efficient MPPT techniques to transfer the maximum available power to the load especially under rapidly changing atmospheric conditions. The thesis reviewed and discussed some existing MPPT controller methods, including constant voltage method, P&O, INC, fractional short-circuit current, fractional open-circuit voltage, etc., and showed their ability to track the MPPT under rapidly changing weather conditions. It illustrated the advantages and disadvantages of each individual MPPT technique tracking performance. Based on the outcome of this evaluation, three proposed MPPT techniques were identified which substantially address the disadvantages that most MPPT techniques suffer from. The three more efficient MPPT controllers proposed were analysed and developed in more depth using new system simulations to clearly show improvements. The first proposed technique is a modified perturb and observe MP&O technique. The P&O MPPT method is very simple in comparison with other techniques, which makes it the easiest to design and implement. However, a P&O method with fixed perturbation step makes it difficult to achieve both a fast response and optimal steady-state operating conditions when atmospheric conditions are changeable.

## References

1. UNEP, "Water Policy and Strategy viewed on," [www.unep.org/dpdl/water/](http://www.unep.org/dpdl/water/) September 2015.
2. UNESCO, "The UN World Water Development Report (2003)," (viewed on [www.unesco.org/water/wwap/wwdr/](http://www.unesco.org/water/wwap/wwdr/), September 2015).
3. UNESCO, "The UN World Water Development Report (2014)," (viewed on [www.unesco.org/water/wwap/wwdr/](http://www.unesco.org/water/wwap/wwdr/), September 2015).
4. A. Z. Sahin and S. Rehman, "Economical Feasibility of Utilizing Photovoltaics for Water Pumping in Saudi Arabia," *International Journal of Photoenergy*, vol. 2012, p. 9, 2012.
5. A. Oi, "Design and simulation of photovoltaic water pumping system," Master Thesis, California Polytechnic State University, 2005.

**International Journal of Advanced Research in Basic Engineering Sciences and Technology (IJARBEST)**  
**Vol.3, Special Issue.24, March 2017**

6.L. A. C. Greenwood, "Green investing: Towards a clean energy infrastructure," WorldEconomic Forum USA Inc, January 2009.

7. M. Thomson, "Reverse-osmosis desalination of seawater powered by photovoltaics without batteries," Doctoral Thesis, Loughborough University, 2003.

8. E. Koutroulis, et al., "Development of a microcontroller-based maximum power point tracking control system," Power Electronics, IEEE Transactions on, vol. 16, pp. 46-54, 2001.

9.T. M. Pavlović, et al., "A review of concentrating solar power plants in the world and their potential use in Serbia," Renewable and Sustainable Energy Reviews, vol. 16, pp. 3891-3902, 2012.

10.Tyagi, et al., "Progress in solar PV technology: Research and achievement," Renewable and Sustainable Energy Reviews, vol. 20, pp. 443- 461, 2013.

11.F. R. Pazheri, et al., "A review on global renewable electricity scenario," Renewable and Sustainable Energy Reviews, vol. 31, pp. 835-845, 2014.

12. J. S. Ramos and H. M. Ramos, "Solar powered pumps to supply water for rural or isolated zones: A case study," Energy for Sustainable Development, vol. 13, pp. 151-158, 2009.

13..P. Purohit and A. Michaelowa, "CDM potential of SPV pumps in India," Renewable and Sustainable Energy Reviews, vol. 12, pp. 181-199, 2008.