

# Design and Analysis of Multi-Band Microstrip Antenna for 5G Applications

Pratyusha Pushadapu<sup>1</sup>, Lavanya Ravi<sup>2</sup>, Bhagya Rani Kasani<sup>3</sup>, Mulagiri Madhu  
Meghana<sup>4</sup>, Bheemireddy Samyuktha<sup>5</sup>

<sup>1,2,3</sup>Assistant Professor, Department of ECE, Bapatla Women's Engineering College, Andhra Pradesh, India.

<sup>4,5</sup>B.Tech Scholar, Department of ECE, Bapatla Women's Engineering College, Andhra Pradesh, India.

Correspondence should be addressed to Pratyusha Pushadapu, pratyu2mail@gmail.com

## ABSTRACT:

The proposed microstrip patch antenna array is designed to operate at 3.6 GHz, which lies in the Sub-6 GHz band used for 5G communication. The antenna is built on a FR4 Epoxy substrate with a 2.2 mm thickness and compact size of 70 mm × 70 mm. A five-element linear patch array is used to achieve higher gain and better directivity. The antenna is excited using a lumped port feed with a 27.18 mm feedline width for proper impedance matching. A 90 mm × 90 mm × 35 mm radiation boundary is applied to simulate accurate far-field radiation. The design is analyzed from 3 GHz to 17 GHz, making it suitable for WiMAX and satellite communication systems.

## Keywords:

Microstrip Patch Antenna, Antenna Array, 3.6 GHz, Sub-6 GHz, 5G, High Gain, FR4 Epoxy, Lumped Port Feed, WiMAX.

## INTRODUCTION:

In recent years, fifth-generation (5G) wireless technology has attracted considerable interest from both academic researchers and industry professionals due to rapid advancements in wireless communication systems. This progress is largely fueled by the growing demand for internet-based applications, high-speed multimedia streaming, and

the extensive use of smartphones [1–4]. 5G technology provides several notable advantages, including ultra-low latency, enhanced Quality of Service (QoS), higher data throughput, increased network capacity, and improved spectral efficiency [5–7]. A major distinction between 5G and previous generations, such as 4G, lies in the utilization of new frequency bands, which facilitates the realization of wider bandwidths and higher data throughput [8]. The 5G spectrum is broadly classified into three main bands: the low band (below 1 GHz), the mid band or sub-6 GHz band, and the high band, which includes millimeter-wave (mmWave) frequencies [9,10]. Among these, sub-6 GHz 5G has attracted considerable interest due to its compatibility with existing 3G and 4G networks, extended coverage range, and reduced susceptibility to signal blockage compared to mmWave frequencies, even when advanced beamforming techniques are employed [11]. Microstrip patch antennas are widely preferred for 5G applications because of their desirable characteristics, such as lightweight structure, low profile, ease of fabrication, low manufacturing cost, and suitability for integration into compact wireless devices [12,13]. However, conventional microstrip patch antennas suffer from certain limitations, including relatively low gain, limited power-handling capability, narrow bandwidth, and surface wave losses [14]. A typical microstrip patch antenna consists of two main components: a radiating patch

and a ground plane, which are printed on the top and bottom surfaces of a dielectric substrate, respectively [15,16]. Various feeding techniques have been developed to excite microstrip antennas, and these can be broadly categorized into contacting and non-contacting methods. Contacting feed techniques transfer power directly to the patch through transmission lines, such as coaxial probes and microstrip feed lines. In contrast, non-contacting or indirect feeding methods rely on electromagnetic coupling between the feed and the patch, including proximity coupling and aperture coupling techniques [17,18].

The primary objective of this work is to design and analyze a compact microstrip patch antenna resonating at 3.6 GHz with acceptable gain and radiation characteristics suitable for sub-6 GHz 5G applications. The proposed antenna is designed with compact dimensions, allowing easy integration into modern small-scale wireless communication devices[19].

**2. Antenna Structure and Design Methodology**

The proposed antenna is composed of four fundamental layers. The top layer acts as the radiating patch, while the bottom layer serves as the ground plane. A dielectric substrate is placed between these two layers to provide mechanical support and electrical insulation. The antenna is energized through a feed port, which ensures proper power delivery. Among these configurations, the rectangular geometry is widely adopted due to its straightforward design process and reliable performance.

To determine the physical dimensions of the rectangular microstrip patch, standard analytical expressions are used [17, 23]. The patch's width is computed using:

**Step 1:** Calculation of the width (W): The patch width is evaluated using the relation:

**Patch width (W):**  $W = c / (2 fr) \times \sqrt{2 / (\epsilon_r + 1)}$   
 .....(1)

Where,  $c$  = Speed of light ,  $f$  = Resonant frequency  
 $\epsilon_r$  = Effective permittivity

**Step 2:** Finding the Effective Dielectric Constant ( $\epsilon_{eff}$ )

**Effective dielectric constant ( $\epsilon_{eff}$ ):**  $\epsilon_{eff} = (\epsilon_r + 1)/2 + (\epsilon_r - 1)/2 \times (1 + 12h/W)^{-1/2}$

$\epsilon_{eff}$  = Effective dielectric constant ,  $\epsilon_r$  = Dielectric constant of substrate ,  $h$  = Height of the dielectric substrate

W = Width of the patch

**Step 5:** Estimation of the Actual Length of the Radiating Patch (L):

The actual length is obtained by: **Actual patch length (L):**  $L = L_{eff} - 2\Delta L$

**Step 6:** Ground Plane Geometry Determination ( $L_g$  and  $W_g$ ), For the design, the ground plane dimensions would be given as:

**Ground plane length:**  $L_g = L + 6h$

**Ground plane width:**  $W_g = W + 6h$

**Step 7:** Determination of strip line feeding:

This antenna design incorporates a stripline-fed excitation technique. The feeding point must be located at that point on the patch where the input impedance is 50 ohms for the resonant frequency

**Resonant frequency:**  $fr = c / (2 L_{eff} \sqrt{\epsilon_{eff}})$

**Microstrip feed line characteristic impedance (Z0):**  $Z_0 = (60 / \sqrt{\epsilon_{eff}}) \ln[(8h/Wf) + (Wf/4h)]$

**Guided wavelength ( $\lambda_g$ ):**  $\lambda_g = c / (fr \sqrt{\epsilon_{eff}})$

**Effective aperture area:**  $A_{eff} = W \times L$

**Approximate antenna gain:**  $G \approx (4\pi A_{eff}) / \lambda^2$

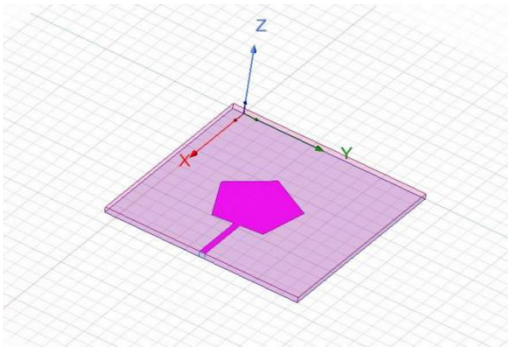

**Figure 1(a):Structural View of the Proposed Antenna Design**

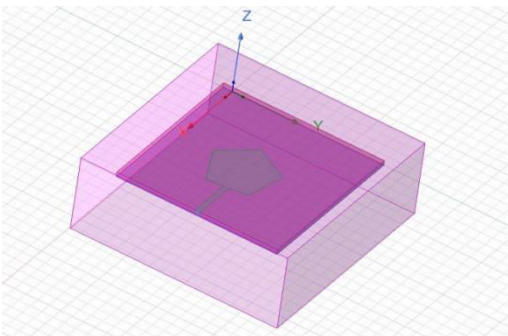

**Figure 1(b): Complete HFSS Simulation Setup of the Proposed Patch Antenna**

The complete HFSS simulation setup of the proposed pentagon-shaped microstrip patch antenna. The antenna consists of a pentagon-shaped radiating patch placed on a rectangular dielectric substrate with finite thickness, backed by a ground plane at the bottom to ensure proper radiation characteristics. The entire structure is enclosed within a surrounding air or radiation boundary, which is used to emulate free-space conditions and minimize unwanted reflections during simulation. The coordinate axes shown in the figure indicate the orientation of the antenna along the X, Y, and Z directions. This simulation setup enables accurate analysis of the electromagnetic performance of the proposed antenna design.

**Table 1:**The Designed Antennas Dimensions

Parameters	Value in (mm)	Parameters	Value in (mm)
Ground plane Width	70	Ground plane Thickness	0
Substrate Width	70	Substrate Thickness	2.2
Patch Width	39.3	Patch Thickness	0.2
Feed line Width	27.18	Feed line Thickness	0.2
Lumped port Width	2	Lumped port Thickness	2.1
Radiation boundary Width	90	Radiation boundary Thickness	35

**The Antenna Results**

The designed multi-band microstrip patch antenna shows effective performance for 5G applications. Overall, the design offers high efficiency, wide bandwidth, and reliable multi-frequency operation.

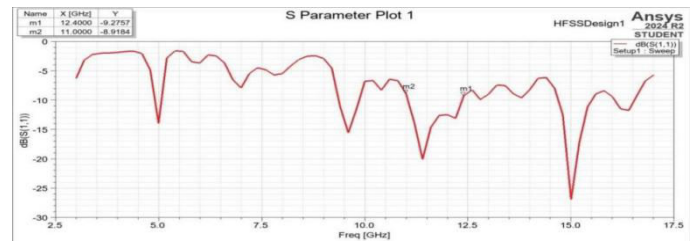

**Figure 2:S-Parameter (Return Loss) Plot of Multi-Band Microstrip Patch Antenna for 5G Applications**

The S-parameter plot shows the reflection coefficient ( $S_{11}$ ) versus frequency for the designed antenna. The antenna resonates at 11 GHz ( $S_{11} \approx -9.82$  dB) and 12.4 GHz ( $S_{11} \approx -9.28$  dB), indicating two main operating bands. At these frequencies, the return loss is below  $-10$  dB threshold for effective radiation, The plot covers 2.5–17.5 GHz, demonstrating the antenna’s wide frequency response. Overall, the results confirm that the antenna can operate efficiently across multiple bands suitable for high-frequency 5G applications.

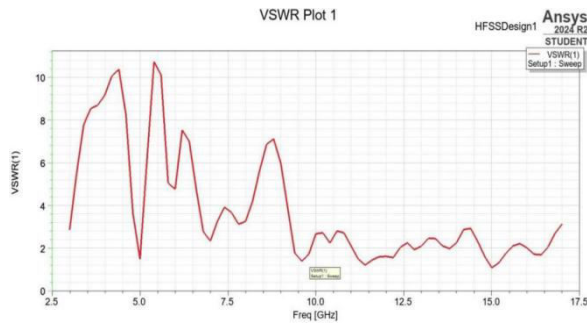

**Fig3:VSWR Characteristics of the Proposed Multi-Band Microstrip Antenna**

The figure illustrates the Voltage Standing Wave Ratio (VSWR) response of the proposed multi-band microstrip antenna over a wide frequency range from approximately 3 GHz to 17.5 GHz. Multiple resonant bands are observed where the VSWR value falls below 2, indicating good impedance matching and efficient power transfer at those frequencies. Higher VSWR peaks correspond to non-resonant regions where impedance mismatch occurs. Overall, the VSWR plot demonstrates stable performance and acceptable matching across the intended operating bands.

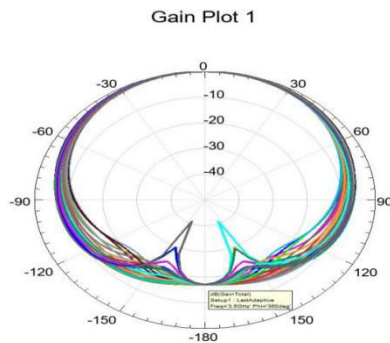

**Fig 4:Radiation Gain Pattern of the Proposed Multi-Band Microstrip Antenna**

The figure shows the radiation gain pattern of the proposed multi-band microstrip antenna obtained from HFSS simulation. The polar plot illustrates the variation of antenna gain with respect to angular direction, indicating the directional radiation characteristics of the antenna. The main lobes are predominantly directed in the broadside direction, which is desirable for wireless communication applications. Minor side lobes and back radiation are also observed,

but their levels remain relatively low. Overall, the gain pattern demonstrates stable radiation performance, making the antenna suitable for 5G applications.

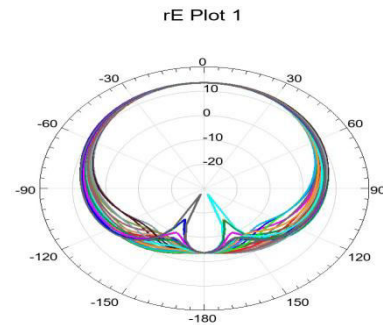

**Fig 5:Radiation Efficiency (rE) Pattern of the Proposed Multi-Band Microstrip Antenna**

The figure illustrates the radiation efficiency (rE) polar plot of the proposed multi-band microstrip antenna obtained through HFSS simulation. The plot represents the angular distribution of radiation efficiency, indicating how effectively the antenna converts input power into radiated energy in different directions. The efficiency is observed to be higher in the main radiation directions, with slight reductions in the back-lobe region. Overall, the rE plot confirms that the antenna exhibits good radiation efficiency and stable performance, making it suitable for 5G wireless communication applications.

## Conclusion

In a multi-band microstrip patch antenna suitable for 5G applications has been successfully designed and analyzed. The proposed antenna demonstrates effective multi-band operation with good impedance matching, as indicated by return loss values below  $-10$  dB and VSWR less than 2 across the operating frequency bands. The antenna exhibits stable radiation patterns, moderate gain, and satisfactory radiation efficiency, making it suitable for sub-6 GHz and higher frequency 5G applications. Owing to its compact size, low profile, lightweight structure, and ease of fabrication, the designed antenna can be easily integrated into modern wireless communication devices. The overall results confirm that the proposed multi-band microstrip patch antenna meets the essential

performance requirements for contemporary 5G wireless systems.

### Future Scope

The proposed antenna design can be further enhanced by incorporating advanced techniques such as slotting, stacking, or the use of parasitic elements to achieve wider bandwidth and higher gain. Reconfigurable antenna designs using PIN diodes, varactor diodes, or MEMS switches can be explored to enable frequency and pattern reconfigurability for dynamic 5G environments. The use of advanced substrate materials with low dielectric loss or flexible substrates may improve efficiency and support wearable or conformal applications. Additionally, the antenna can be extended to multiple-input multiple-output (MIMO) configurations to improve data rates and reliability in 5G systems. Integration of the antenna with millimeter-wave bands and compact antenna arrays can also be investigated to support future beyond-5G and 6G wireless communication technologies.

### REFERENCE

- [1]. Z., Chen, Z., Xiao, L., and Yuan, T. (2020). Co-located self-neutralized Journal of Engineering and Sustainable Development (Vol. 28, No. 02, March 2024) ISSN 2520-0917 291 handset antenna pairs with complementary radiation patterns for 5G MIMO applications. IEEE Access. Vol.8, pp. 73151-73163. <https://doi.org/10.1109/access.2020.2988072>.
- [2]. Zhu, S., Liu, H., Chen, Z., & Wen, P, (2018). For 5G millimeter-wave applications, a small gain-enhanced Vivaldi antenna array with decreased mutual coupling. IEEE Wireless Propagation Letters and Antennas. Volume 17, Issue 5, pp. 776-779. <https://doi.org/10.1109/lawp.2018.2816038>.
- [3]. Pratyusha Pushadapu, M.Shiva Kumar, "Analysis of A L-Shaped Microstrip Patch Antenna for 5G Applications," International Journal of Microwave and Optical Technology (IJMOT), 2024.
- [4]. Pratyusha Pushadapu, Sunil Kumar, "Microstrip Patch Antenna with Defected Ground Structure (DGS) for ISM and Sub-6 GHz Applications," International Journal of Selected Topics in Microwave and Optical Technology (IJMOT), 2024.
- [5]. Khalid Jassim, A., & Nghaimesh, A. (2024). Triple-Band Circular Patch Microstrip Antenna for Wireless Communication. Journal of Engineering and Sustainable Development, Vol. 28, Issue 1, pp.65–75. <https://doi.org/10.31272/jeasd.28.1.5>
- [6]. Hikmat Abd, R., & A Abdulnabi, H. (2023). Reconfigurable graphene-based multi-input-multi-output antenna for sixth generation and biomedical application. Journal of Engineering and Sustainable Development, Vol. 27, Issue 6, pp.798–810. <https://doi.org/10.31272/jeasd.27.6.10>
- [7]. AbdulKareem, A. and M.J. Farhan. (2020). A novel MIMO patch antenna for 5G applications. Materials Science and Engineering, IOP Conference Series. IOP Publishing. <https://doi.org/10.1088/1757-899x/870/1/012040>.
- [8]. Mushin, M.Y., J.K. Ali, and A.J. Salim, (2022). A four-element, compact, high-isolation MIMO antenna system for 5G mobile devices. Engineering and Technology Journal. Vol. 40, Issue. 08, pp. 1055-1061. <https://doi.org/10.30684/etj.2021.131103.1004>.
- [9]. Basil Nassir, R. ., & Khalid Jassim , A. (2022). MIMO antenna design for wireless communication applications. Engineering and Sustainable Development Journal, Vol. 26, Issue 4, PP:36–43. <https://doi.org/10.31272/jeasd.26.4.4>
- [10]. Zhang, Y. H., Spiegel, R. J., Fan, Y., Joines, W. T., Liu, Q. H., and Da Xu, K. (2014). creation of a ring-resonator slot with a stub for use in antenna applications. IEEE Antenna and Propagation Transactions. Volume 63, Issue 2, pages. 517-524. <https://doi.org/10.1109/tap.2014.2382646>.
- [11]. Marcus, M.J., (2015). 5G and" IMT for 2020 and beyond"[Spectrum Policy and Regulatory

- Issues]. IEEE Wireless Communications. Vol. 22, Issue 4, pp. 2-3. <https://doi.org/10.1109/mwc.2015.7224717>.
- [12]. Kapoor, A., R. Mishra, and P. Kumar. (2021). Innovative surface-based space-borne filters with broad frequency selectivity for sub-6 GHz 5G devices. The Fourth Biennial International Conference on Nascent Technologies in Engineering (ICNTE) will take place in 2021. IEEE. <https://doi.org/10.1109/icnte51185.2021.9487649>.
- [13]. Olawoye, T.O. and P. Kumar. (2020). A high gain microstrip patch antenna with slotted ground plane for sub-6 GHz 5G Journal of Engineering and Sustainable Development (Vol. 28, No. 02, March 2024) ISSN 2520-0917292 communications. In 2020 International Conference on Artificial Intelligence, Big Data, Computing and Data Communication Systems (icABCD). IEEE. <https://doi.org/10.1109/icabcd49160.2020.9183820>.
- [14]. Waterhouse, R., (2003). A Designer's Guide to Microstrip Patch Antennas. Springer, Science & Business Media. ISBN: 1402073739.
- [15]. Pozar, D.M., (1985). microstrip antenna connected to a microstripline via an aperture. Electronics letters. Vol. 21, Issue 2, pp. 49. <https://doi.org/10.1049/el:19850034>.
- [16]. Sainati, R.A., (1996). Microstrip antenna CAD for wireless applications. Artech House, Inc. ISBN: 0890065624.
- [17]. Prasanna, M., Ahmed, M.R., and Rakesh (2018). Design of Dual-band Microstrip antenna for WiMax and X band applications. In 2018 The Second International Conference on Green Computing and the Internet of Things (ICGCIoT). IEEE. <https://doi.org/10.1109/icgciot.2018.8753080>.
- [18]. Aneesh, M., Siddiqui, M. G., Ansari, J. A., & Singh, A. (2016). Inset Feed Topped H-Shaped Microstrip Patch Antenna for PCS/WiMAX Application. Indonesian Journal of Electrical Engineering and Computer Science, Vol. 1, no. 2, pp. 365-370. <https://doi.org/10.11591/ijeecs.v1.i2.pp365-370>.
- [19]. Balanis, C.A., (2015). Antenna theory: analysis and design. John Wiley & sons. ISBN: 1119178991.
- [20]. Thaher H., R. (2016). Rectangular Microstrip Patch Antenna Design for Wireless Communication Systems. Engineering and Sustainable Development Journal, Vol. 20, Issue 1, pp.90–101.
- [21] S. Ershadi, A. Keshtkar, A. H. Abdelrahman, and H. "Wideband high gain antenna subarray for 5G applications," Xin Electromagnetics Research Progress C, vol. 78, pp. 33–46, 2017, doi: 10.2528/pierc17061301.
- +