

## RESCUE SYSTEM FOR COAL MINE WORKERS USING RASH BERRY PI PROCESSOR DIFFERENT SENSORS BASED ON GSM

HARIRAJ.V<sup>1</sup> DIWAHAR.A1 KARTHICK.V1, K .KOKILA <sup>2</sup>

UG Scholar<sup>1</sup>, Asst.Professor<sup>2</sup> Dept. of ECE  
SCAD institute of technology  
anengineerhari@gmail.com<sup>1</sup>, diwaharece002@gmail.com<sup>1</sup>, karthickv62@gmail.com<sup>1</sup>,  
Kokilakarupusamy18@gmail.com<sup>2</sup>

### ABSTRACT

In this paper we have a tendency to are implementing police investigation, safety measures for mine staff that is most essential in underground mining areas/sections Here we have a tendency to are presenting based mostly sensors network used to monitor the setting parameters of underground mine space and sends All perceived parameters/data to Rash berry pi processor. the underground management center to monitor and to take necessary immediate action to avoid damages and alerts through a mobile message.

Index Terms—Sensors Network, MEMS,GSM,PC, Raspberry Pi

### INTRODUCTION

Safety of person is primary concern/aspect in any business, particularly in underground mining business. To avoid any kind of unwanted phenomena, all mining business follows some basic precaution and phenomena. In underground mine major of accidents occurred square measure primarily based on fireplace and natural gas and warming of surroundings. we tend to square measure additionally considering the health condition of a person victimization Fall-Detector, manufactured from MEMS-Accelerometer (ADXL335).Coal mine safety watching system primarily based on wireless sensing element network will timely and accurately mirror dynamic state of affairs of employees in the underground regions to ground laptop system. The hybrid subway radio propagation model comprising of the free area propagation and the changed wave guide propagation is planned. However, victimization fashionable radio communication within underground mines has some drawbacks. whereas radio signals square measure transmitted, attenuation, optical phenomenon, multi -path and scattering square measure often terribly serious. Thus, wireless communication is the vital want these days for the quick, versatile safety, correct and production technique in underground mines.

There square measure totally {different| completely different} different analysis concepts planned by different folks on wireless communication. In a network referred to as chain-type wireless underground mine sensing element network (CWUMSN) is recently planned that consists of 3 types of sensing element nodes: sensing nodes, cluster head nodes, and a base station deployed on each side of the tunnel at regular intervals to observe the underground atmosphere and find the miners. a brand new call -making approach to coal and gas Outburst prediction with multisensory data fusion is planned. this technique is style by considering of these parameters i.e. it will sense temperature, pressure, humidity, Fire, Gas yet as Persons Fall. thus the designed system is giving a really sensible resolution for many of the issues moon-faced in mine accidents. an honest communication system should be set between mine employees and Remote Base Station For this wired network communication is inefficient in underground mining areas. therefore we tend to square measure selecting a wireless network system supported GSM additionally we tend to victimization GSM networks for causing SMS to fireside and automobile

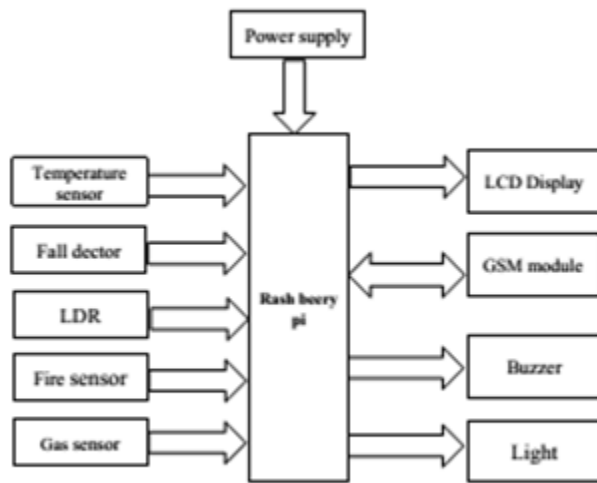

Fig 1 Block diagram Representation of Mine Section

## DESCRIPTION OF THE SCENARIO

The projected system is split into 2 segments. First is a hardware circuit which will be connected with the body of the Mine staff. it's going to be ideally fitted with the safe helmet of the staff also. This system has a sensing element module consisting of some sensors that measures time period underground parameters like vital sign, measuring system, LDR, fireplace sensing element and Gas concentration. Excess Gas concentration is supposed for the harmful gases like alkane series, Carbon-monoxide, alkane and gas Microcontroller is used with the sensing elements to receive the sensor outputs and to take the necessary call. If vital sign is over the protection level pre-programmed at microcontroller, the controller decodes beep alarms through the speaker connected with controller. Once the measured equally once gas concentration crosses the safety level, microcontroller decodes siren alarms. Once person falls down for any reason measuring system can offer alert through GSM and alarm can offer corresponding beep alerts. LDR sensing element senses the sunshine intensity and counting on the sunshine intensity lights are flip -on

or turn-off. Fireplace sensing element plays a job of detection fireplace accidents and provides responsive to base station that helps in taking necessary precautions. A 16x2 character digital display module is interfaced to show all the parameters like vital sign at underground MINER'S module's electronic equipment is interfaced to the Module to send message to the fireplace station whenever there is fireplace accident in underground mine and conjointly sends message to motorcar service if the person remains in Fall Position for massive period

## RASPBERRY PI PROCESSOR

The Raspberry Pi could be a series of credit card-sized single-board computer. All Raspberry Pi is embrace identical Video Core IV graphics process unit (GPU) and either a single-core ARMv6-compatible C.P.U. or a more recent ARMv7-compatible quad-core one (in Pi 2) and one GB of RAM (in Pi 2), 512 MB (In Pi one models B and B+) or 256 MB (in models A and A+, and within the older model B).They have a Secure Digital (SDHC) slot (models A and B) or a Micro SDHC one (models A+, B+, and Pi 2) for boot media and protracted storage, It is conjointly having local area network package employed in Raspberry Pi Windows ten, Additional distributions of UNIX like Ubuntu, Python because the main artificial language, with support for BBC BASIC (via the computer architecture OS image or the hard drink Basic clone for Linux), C, C++, Java, Perl, Ruby, Squeak Smalltalk and a lot of conjointly obtainable

## POWER SUPPLY

The power offer unit features a 5v offer. it's a pure dc offer during which the provision is given to the measuring instrument sensors, digital display displays, microcontroller, ADC circuits.

## SENSOR NETWORK

### 1) Body Temperature Sensor

### Fig 2 Sensors in Sensor Network

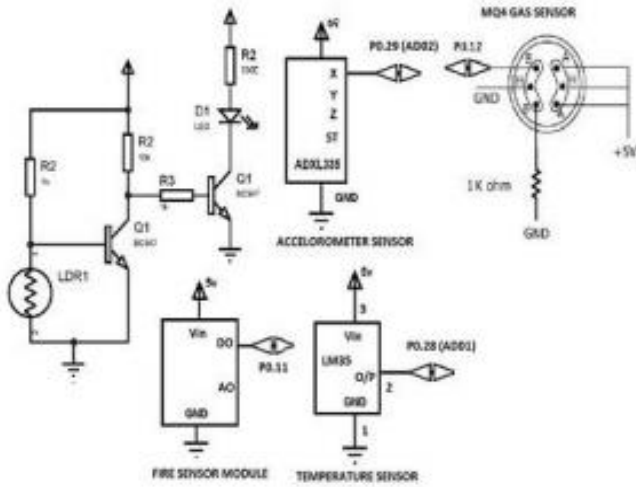

detector detects the hearth then it became short-circuit. Once there's no hearth the detector become electric circuit. The detector works on the principle of IR rays or Heat radiation detection.

#### 4) MQ-4 Semiconductor Sensor for Natural Gas

For detection of methane series, conjointly to fuel and alkane series that square measure the key toxicant gases in underground coal mines, MQ-4gas detector is employed. MQ-4 has half dozen pins; four of them square measure wont to fetch signals and alternative two square measure used for activity heating current. A gas detector may be a device that detects the presence of varied gases among a locality, sometimes as a part of a system to warn concerning gases which could be harmful to humans or animals. Gas notices will be wont to detect flammable, toxic, and oxygen' and carbon dioxide gases.

#### 5) Light Dependent Resistor (LDR)

In this system LDR is use to sense the darkness in Underground mining section. If the operating space is dark then LDR triggered circuit can activate the light-emitting diode lights gift on staff Helmet. This arrangement provides the system to possess sensible battery backup and conjointly provides win over to jack.

#### GSM MODULE

The transmit signal of port of microcontroller is connected with transmit signal (TxD) of the serial interface of GSM electronic equipment whereas receive signal of microcontroller port is connected with receive signal (RxD) of serial interface of GSM electronic equipment Compared with causing SMS through electronic equipment in PDU Mode. Plain Text message is also sent through the electronic equipment by interfacing solely 3 signals of the serial interface of electronic equipment with microcontroller (TxD, RxD and GND). During this theme RTS and CTS signals of port interface of GSM electronic equipment are connected with each other.

In the planned system we tend to use LM35 that may be a exactitude IC temperature detector with associate degree output voltage linearly proportional to Centigrade temperature. A electrical device| semiconductor device| semiconductor unit| semiconductor} may be a kind of resistor wont to live temperature changes, hoping on the modification in its resistance with dynamic temperature. electrical device| semiconductor device| semiconductor unit| semiconductor} may be a combination of the words thermal and resistor. The ADC of LPC2148 can convert analog worth into digital worth and this digital worth.

#### 1) MEMS Accelerometers (ADXL335):

The ADXL335 may be a low power, thin, small, complete 3-axis measuring instrument with signal conditioned voltage Outputs. Product processes acceleration with a minimum complete vary of  $\pm 3$  g. They'll live the static Acceleration of gravity in tilt-sensing device, still as Dynamic acceleration ensuing from vibration, shock, or Motion. coordinate axis is connected with controller and endlessly Checks that „g“ worth modification.

#### 3) Fire sensor:

The detector is employed to notice any trace of fireplace and it'll give interrupt signal as before long because it detects hearth in underground regions. The flame detector is employed to notice the flame prevalence. Once the detector detects the hearth then it became short-circuit. once there's no hearth the detector become electric circuit. The flame detector is employed to notice the flame prevalence. Once the



Fig 3.GSM Module



Fig 4 Fire Station Mobile Section

### LCD INTERFACING

liquid crystal {display |LCD |digital display |alphanumeric display} (Liquid Crystal Display) screen is associate degree electronic display module and notice a good vary of applications. A 16x2 liquid crystal {display |LCD |digital display| alphanumeric display} display is extremely basic module and is extremely unremarkably utilized in numerous devices and circuits. These modules are most well-liked over seven sections and alternative multi segment LEDs. the explanations being: LCDs ar economical; simply programmable; don't have any limitation of displaying special & even custom characters (unlike in seven segments), animations and then on.

### RESULTS

The Overall system's results square measure given during this section. The Raspberry pi board that is shown in below figure is heart of all functionalities in laborer module i.e. Monitoring, process collected knowledge and taking necessary action supported the boundaries given for individual sensors In the following Figure all sensors and modules are connected to create the primary paradigm of our planned system

On detection of Abnormal activity at laborer module the core system alerts and sends SMS to either fireplace station or car supported the Interrupt supply. SMS is shipped to fireplace station once fireplace accident occurred within the underground space. equally SMS is shipped to car if Person is fallen down.

### CONCLUSIONS

The present Mine security system will be effectively replaced by this rescue safety system planned during this paper. Our system coated the most necessary and Primary necessity side of any mine employees safety. The observation of depth and dangerous mines is formed simple with this paper.

As we have a tendency to are exploitation Low power RF transmission and lamp control circuit ton of power utilization is reduced, that is most necessary for any system that run on Battery. additional security is provided by GSM, wont to send message to fireplace and car. of these sensors may be simply placed on Miner's Helmet that helps in continuous observation.

### REFERENCES

- [1] E. K. Stanek, "Mine Electro technology Research: The Past 17 Years", IEEE transactions on industry applications, vol. 24(5), pp 818-19, 1988.
- [2] S. Wei, L. Li-li, "Multi-parameter Monitoring System for Coal Mine based on Wireless Sensor Network Technology", Proc. International IEEE Conference on Industrial Mechatronics and Automation, pp 225-27, 2009
- [3] Y.P. Zhang, G. X. Zheng, J. H. Sheng, "Radio Propagation at 900 MHz in Underground Coal Mines", IEEE transactions on antennas and propagation, vol.49(5), pp. 752-62, 2001.

[4] S. Jin-ling, G. Heng-wei, S. Yu-jun, "Research on Transceiver System of WSN Based on V-MIMO Underground Coal Mines", Proc. International Conference on Communications and Mobile Computing, pp 374-378, 2010.

[5] N. Chaamwe, W. Liu, H. Jiang, "Seismic Monitoring in Underground Mines: A case of Mufulira Mine in Zambia Using wireless Sensor Networks for Seismic Monitoring", Proc. IEEE international Conference on Electronics and Information Engineering, vol. 1(V1), pp 310-14, 2010.

#### BIBLIORAPHY



Diwahar.A pursuing the Bachelor of Engineering in Electronics and Communication at SCAD Institute of technology, palladam. His area of interest is Embedded system, networking, digital image processing.



Hariraj.V Pursuing the Bachelor of Engineering in Electronics and Communication at SCAD institute of technology, Palladam, The area of interest in VLSI, embedded systems, digital image processing development. His future research interest in digital image processing development, embedded systems, and wireless sensor networks.



Karthick.v Pursuing the Bachelor of Engineering in Electronics and Communication at SCAD institute of technology, Palladam, His area of interest is Embedded system, networking, digital image processing.

Ms Kokila.ME whose project guidance of our project completed. Bachelor of Engineering and Master of Engineering. Her area of interest is Embedded system, networking, digital image processing

