

# HEART RATE AND SP02 MONITORING USING MIT APP INVENTER

SHUNMUGALAKSHMI.G / AP / NATIONAL ENGINEERING COLLEGE,  
MEENAKSHISUNDERESWARAN.U / EEE/ NATIONAL ENGINEERING COLLEGE,  
VIGNESH.K / EEE / NATIONAL ENGINEERING COLLEGE,  
VENKADESHAPERUMAL.S / EEE / NATIONAL ENGINEERING COLLEGE,  
VINITH.A.N. / EEE / NATIONAL ENGINEERING COLLEGE

**Abstract-** For today's modern world, we have designed a health monitoring system using the MAX30102 sensor. In this project, a mobile application is developed with which patient can measure their oxygen saturation and heart rate at home and the measured data can be saved for future reference. The measurement of both spo2 and heart rate gives a person stress level in real-time which helps to overcome depression. The major examination of this study is to find the readings in BPM (beat per minute) in our body. Monitoring Heartbeat is important for athletes, patients, elderly people. It helps elderly people and patients with a disease such as tuberculosis, asthma, hypertension, stress, heart attack, lung cancer. This project helps to view the output in the smartphone app and data is stored in the smartphone which can be used for health analysis. Hence, this system helps to achieve high probability, high functionality, at a low cost.

**Keywords:** Bpm-beat per minute, Spo2-Oxygen saturation, PPG-Photoplethysmography.

## I. Introduction

Normally people won't check the heart rate and blood oxygen until it is just too late at that point it becomes too difficult to cure. Low blood oxygen saturation is that the indication of many diseases like Tuberculosis, Anemia, lung cancer, asthma, pneumonia, etc., and the low pulse is that the indication of diseases like heart-attack, sick sinus syndrome, and certain infection like Lyme disease or typhoid and other diseases like the high level of potassium in the blood (hyperkalemia) and underactive thyroid and the fast pulse is that the indication of cardiomyopathy, ventricular tachycardia, low level of thyroid in the blood(hypokalemia), anemia, asthma or breathing trouble. Thus our low-cost battery operates pulse oximeter can detect these diseases early and save peoples money, suffering, and their precious life. Normally people would feel difficulty in breathing when spo2 falls below 95 percent but thanks to the covid-19 disease they only feel when it falls below a very dangerous level. Photoplethysmography(PPG) may be a low-cost optical technique that's ready to detect volumetric changes in blood flowing through capillaries from the skin surface by emitting then absorbing a light-weight wave passing through blood vessels (or capillaries) within the fingertip. A variation of the sunshine wave passing through the finger will give the price of the SpO2. Photoplethysmography was developed within the late 1800s where scientists observed real-time blood flow using light bulbs. it had been within the late 1930s that the term "photoplethysmography" was coined by scientists. With the advancement in technology, PPG developments now specialize in consumer applications using wearable devices. In this work, our blood oxygen saturation and heart rate are measured using Max30105. And Arduino code is developed for collecting data from the sensor and display it in a serial monitor. The android application is developed using MIT app inventor to send data from a serial monitor and display it in an android application.

## II. METHODOLOGY:

Pulse oximetry is typically a fairly accurate test. This is very true when using high-quality equipment found in most medical offices or hospital settings. It consistently provides results within a 2-percent difference either way of what it truly is. If your reading was 82 percent, for instance, your true oxygen saturation level could also be anywhere from 80 to 84 percent. However, the standard of the waveform and assessment of the individual must be considered. Factors like movement, temperature, or nail enamel can impact the accuracy. Typically, quite 89 percent of your blood should be carrying oxygen. This is the oxygen saturation level needed to stay your cells — and your body — healthy. While having an oxygen saturation below this temporarily isn't believed to cause damage, repeat or consistent instances of lowered oxygen saturation levels could also be damaging. An oxygen saturation level of 95 percent is taken into account as normal for many healthy individuals. A level of 92 percent indicates potential hypoxemia or deficiency in oxygen reaching tissues within the body.

Our sensor(MAX30105)has two lights infrared and red light and photodetector which sense reflected light wave. oxygenated hemoglobin in our blood absorbs more infrared light and red light easily passes through blood and vice-versa for deoxygenated hemoglobin. And heart rate by calculation flow of blood by taking an average of four or six beats by Beer Lambert's Law

$$I_{out} = I_{in} e^{-\mu l}$$

$$\text{Heart rate} = (\text{no of pulse} * 60) / T$$

$$\text{SpO}_2 = (\text{max}_{red} / \text{min}_{red}) / (\text{max}_{ir} / \text{min}_{ir})$$

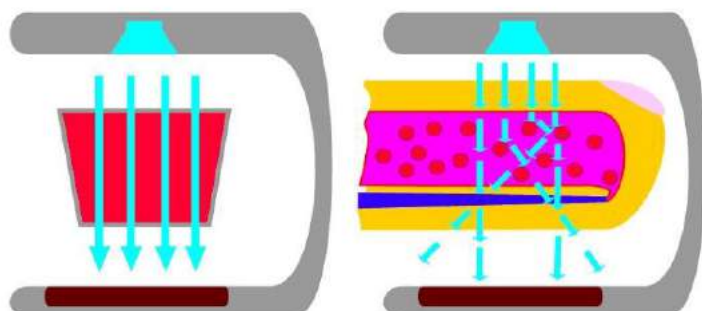

Figure 1. oxygenated haemoglobin in our blood absorbs more infrared light and red light easily passes through blood and vice-versa for deoxygenated haemoglobin

## III. COMPONENTS DESCRIPTION:

### A Arduino UNO:

The Arduino UNO is the best board to get started with electronics and coding. If this is your first experience tinkering with the platform, the UNO is the most robust board you can start playing with. The UNO is the most used and documented board of the whole Arduino family



FIGURE 2. ARDUINO UNO

Arduino Uno is a microcontroller board based on the ATmega328P. It has 14 digital input/output pins (of which 6 can be used as PWM outputs), 6 analog inputs, a 16 MHz ceramic resonator (CSTCE16M0V53-R0), a USB connection, a power jack, an ICSP header, and a reset button. It contains everything needed to support the microcontroller; simply connect it to a computer with a USB cable or power it with an AC-to-DC adapter or battery to get started. You can tinker with your Uno without worrying too much about doing something wrong, in the worst-case scenario you can replace the chip for a few dollars and start over again.

"Uno" means one in Italian and was chosen to mark the release of Arduino Software (IDE) 1.0. The Uno board and version 1.0 of Arduino Software (IDE) were the reference versions of Arduino, now evolved to newer releases. The Uno board is the first in a series of USB Arduino boards, and the reference model for the Arduino platform; for an extensive list of current, past, or outdated boards see the [Arduino index of a board](#).

#### B. Bluetooth module:

HC-05 is a Bluetooth module that is designed for wireless communication. This module can be used in a master or slave configuration. Bluetooth serial modules allow all serial-enabled devices to communicate with each other using Bluetooth. It has 6 pins,

Key/EN: It is used to bring Bluetooth module in AT commands mode. If the Key/EN pin is set to high, then this module will work in command mode. Otherwise, by default, it is in data mode. The default baud rate of HC-05 in command mode is 38400bps and 9600 in data mode.

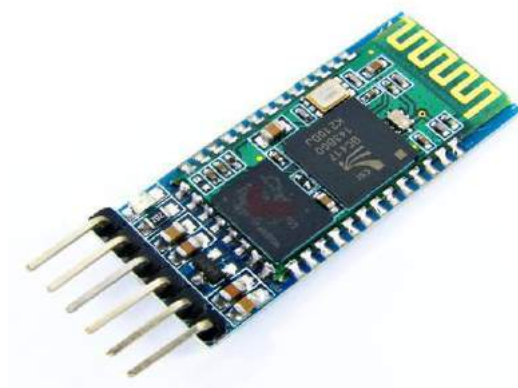

FIGURE 3. HC-05 Bluetooth Module

C. Pin configuration :



FIGURE 4 PIN CONFIGURATION

Table I: Pin Configuration

Pin Number	Pin Name	Description
1	Enable / Key	This pin is used to toggle between Data Mode (set low) and AT command mode (set high). By default, it is in Data mode
2	Vic	Powers the module. Connect to +5V Supply voltage
3	Ground	Ground pin of module, connect to system ground.
4	TX – Transmitter	Transmits Serial Data. Everything received via Bluetooth will be given out by this pin as serial data.
5	RX – Receiver	Receive Serial Data. Every serial data given to this pin will be broadcasted via Bluetooth
6	State	The state pin is connected to an onboard LED, it can be used as feedback to check if Bluetooth is working properly.
7	LED	Indicates the status of Module Blink once in 2 sec: Module has entered Command Mode Repeated Blinking: Waiting for connection in Data Mode

		Blink twice in 1 sec: Connection successful in Data Mode
8	Button	Used to control the Key/Enable pin to toggle between Data and command Mode

D. MAX30102 SENSOR:

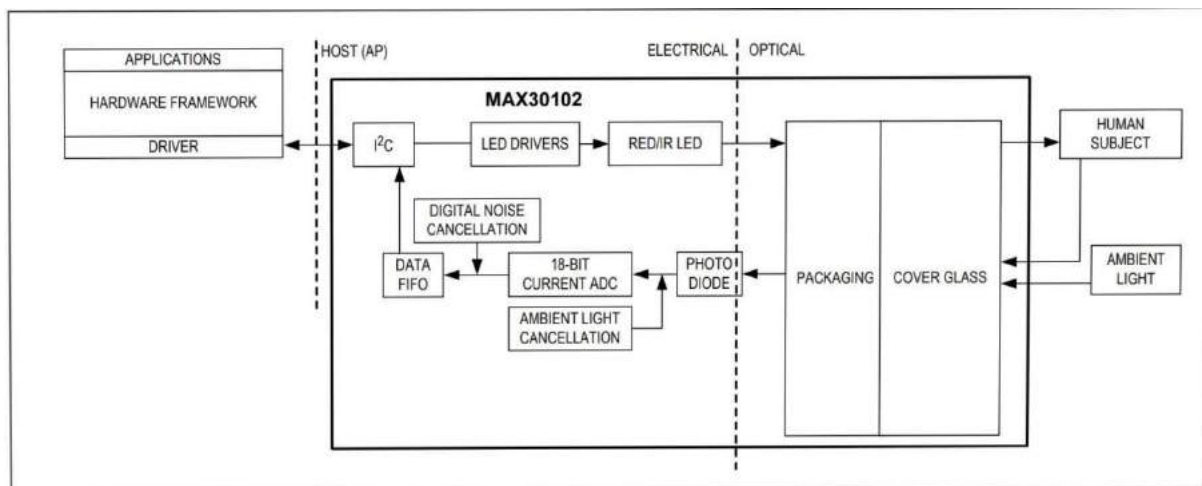

FIGURE 5 MAX30102 SENSOR

MAX30105 Particle Sensor is a flexible, powerful sensor enabling sensing of distance, heart rate, particle detection, and even the blinking of an eye. The MAX30105 has been equipped with three LEDs as well as a very sensitive photon detector. The idea is to pulse the different LEDs, then detect what shines back. Based on the reflected signature it's possible to detect different types of particles or materials (such as oxygenated blood or smoke from a fire).

The MAX30105 utilizes a red LED, a green LED, and an IR (Infrared) LED for presence sensing, heart-beat plotting and heart-rate monitoring among it operates at 5V and can communicate with both 3.3V and 5V microcontrollers. We've also written an Arduino library for the MAX30105 Breakout which takes care of all of the I2C communication, bit shifting, register writing, and sample reading.

The multitude of uses, including Pulse Oximetry. The MAX30105 is designed to MAX30105 has three LEDs. On the right is a very sensitive photon detector. The idea is that you obstruct the different LEDs, detecting what light shines back at the detector, and, based on the signature, you can tell the presence of different types of particles or materials (such as oxygenated blood or smoke from a fire).

Table II: pin label description

Pin Label	Input/Output	Description

INT	Output	Interrupt, active low
GND	Supply Input	Ground (0V) supply
5V	Supply Input	Power supply
SDA	Bi-directional	I <sup>2</sup> C bus clock line
SCL	Input	I <sup>2</sup> C bus clock line

#### E. Arduino IDE

It is an open-source Arduino Software (IDE) that makes it easy to write code and upload it to the board. Arduino is an open-source electronics platform based on easy-to-use hardware and software. Arduino board can read inputs - light on a sensor, a finger on a button, or a Twitter message - and turn it into an output - activating a motor, turning on an LED, publishing something online. You can tell your board what to do by sending a set of instructions to the microcontroller on the board. To do so you use the Arduino programming language (based on wiring), and the Arduino software (IDE), based on processing.

#### IV. Mit App Inventor

MIT App Inventor is an intuitive, visual programming environment that allows everyone – even children – to build fully functional apps for smartphones and tablets. Those new to MIT App Inventor can have a simple first app up and running in less than 30 minutes. And what's more, our blocks-based tool facilitates the creation of complex, high-impact apps in significantly less time than traditional programming environments. The MIT App Inventor project seeks to democratize software development by empowering all people, especially young people, to move from technology consumption to technology creation.

Blocks-based coding programs inspire intellectual and creative empowerment. MIT App Inventor goes beyond this to provide real empowerment for kids to make a difference -- a way to achieve the social impact of immeasurable value to their communities.

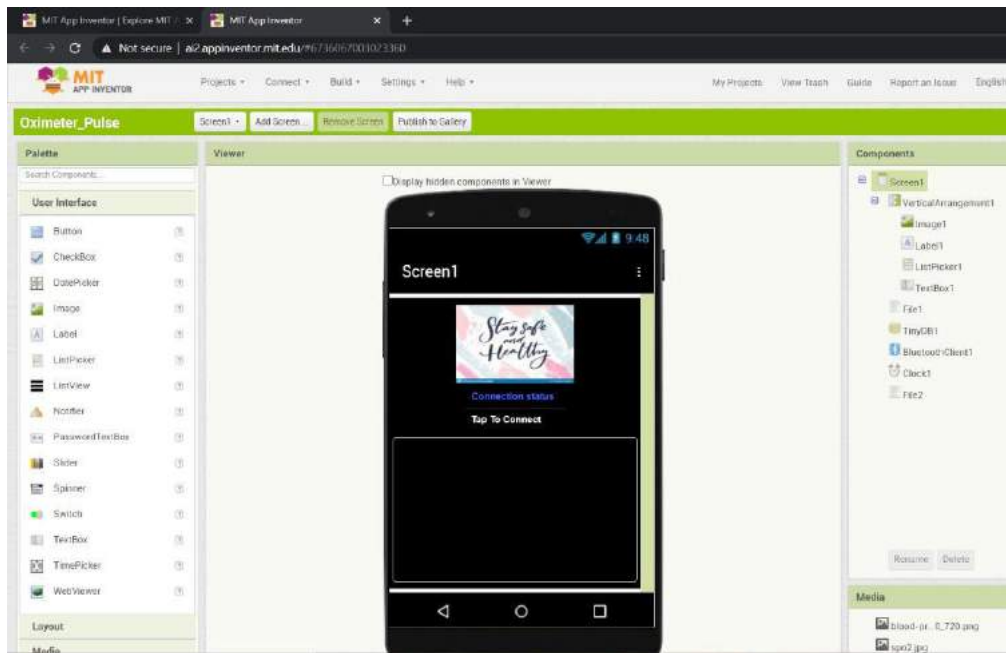

Figure 6 MIT App Inventor

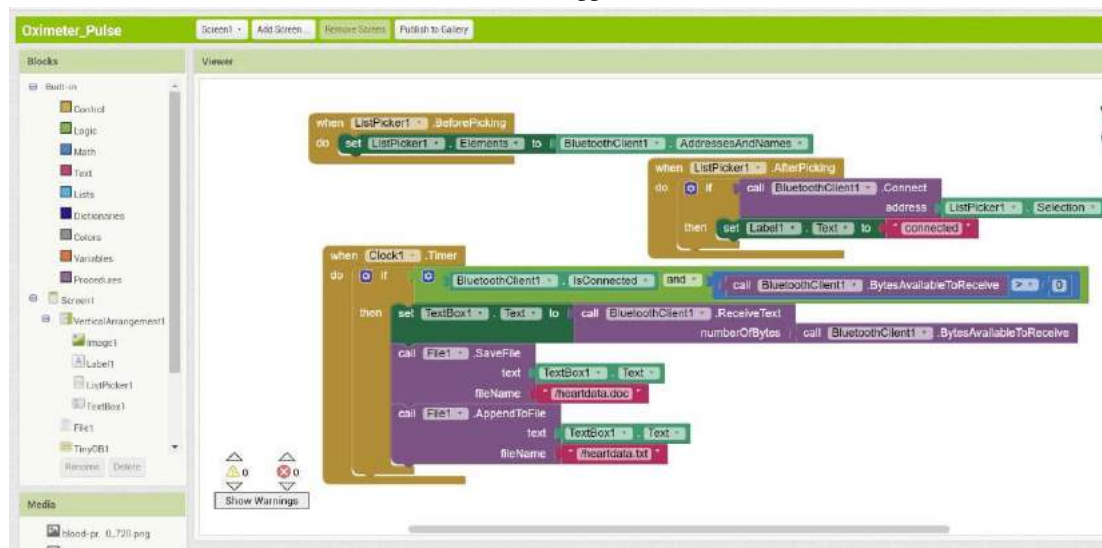
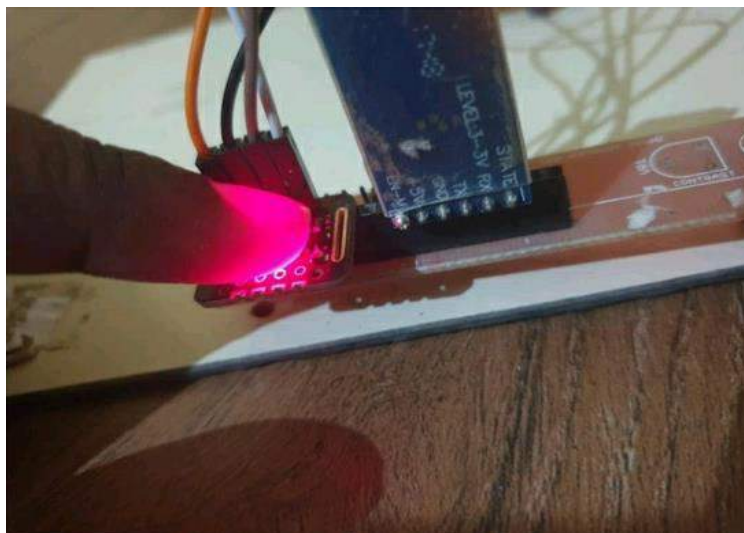

Figure 7. MIT android application

## V. RESULTS AND DISCUSSION

The designed system has been Compared between the commercially available and designed system for monitoring Heart rate, SpO2, and Temperature has been done. The performance of the system is satisfactory. The system is compact, portable, and user-friendly. This system is applicable for family, hospital centers, community medical treatment, sports healthcare, and other medical purposes.



**Figure 8..** Final view of project

Table III: SPO2 READING TABULATION:

S.NO	Pulse oximeter reading(spo2 in %)	project reading(spo2 in percentage)	Error percentage (%)
1.	97	95	-2
2.	98	100	2
3.	96	94	-2

Table IV: HEARTBEAT TABULATION:

S.NO	ECG(BPM)	project reading (heartbeat in bpm)	ERROR PERCENTAGE(%)
1.	58	56	-2
2.	59	61	2
3	60	58	-2





Figure 9. Output Display

## VI. CONCLUSION

A Health monitoring system is designed to measure and analyze the data of heart rate, spo2 and temperature. This is a portable, feature-rich and less expensive compared to normal ones. Also, the result from the system is quite impressive and accurate with minimum error. They can be improved as a wearable that detects abnormalities to warn families or call emergency service also a person with no technical knowledge can operate this and can be benefited.

## REFERENCE

1. R.K.Parate, S.J.Sharma: Design of a Portable Health Monitoring System Based on Node MCU. (IJAT: International Journal of Engineering and Advanced Technology) ISSN: 2249 – 8958.
2. Mohamed Fezari, Mounir Bousbia-Salah, and Mouldi Bedda: Microcontroller Based Heart Rate Monitor. The International Arab Journal of Information Technology, Vol. 5, No. 4.
3. Mina Patil, Abhishek Madankar, Dr. P. D. Khandait: Heart Rate Monitoring System. IEEE ISSN:2469-5556
4. R. R. Adiputra, S. Hadiyoso, Y. Sun Hariyani: Internet of Things: Low Cost and Wearable SpO2 Device for Health Monitoring. IJECE(International Journal of Electrical and Computer Engineering).
5. Sahanas Khamister, prof. MohammedAfi: Iot Based system For Heart Rate Monitoring. IJERT(International Journal of Engineering Research and Technology). Vol no.9, Issue no.7
6. ChaoLi, Xiangpei Hu, Lili Zhang: Iot Based Disease Monitoring System For Pervasive Health Care System. Procedia Computer Science. Volume 112.

7. Kiran Dewangan, Dr, Mina Mishra: Internet of Things for Healthcare: A Review by. International Journal of Advanced in Management, Technology and Engineering Sciences. ISSN: 2249-7455.
8. M. Sathya, S. Madhan, K. Jayanthi: Internet of things (IoT) based health monitoring system and challenges. International Journal of Engineering & Technology. 2018.